

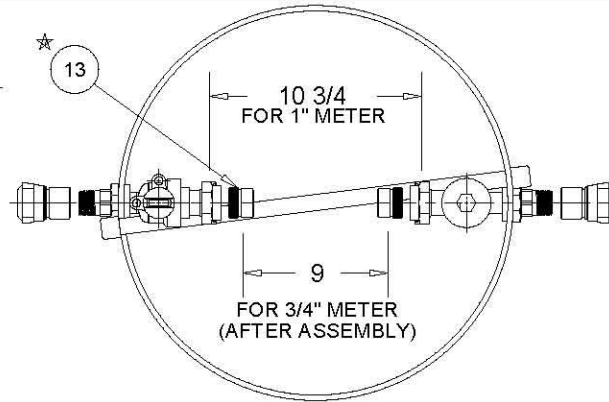

A-C10804-01

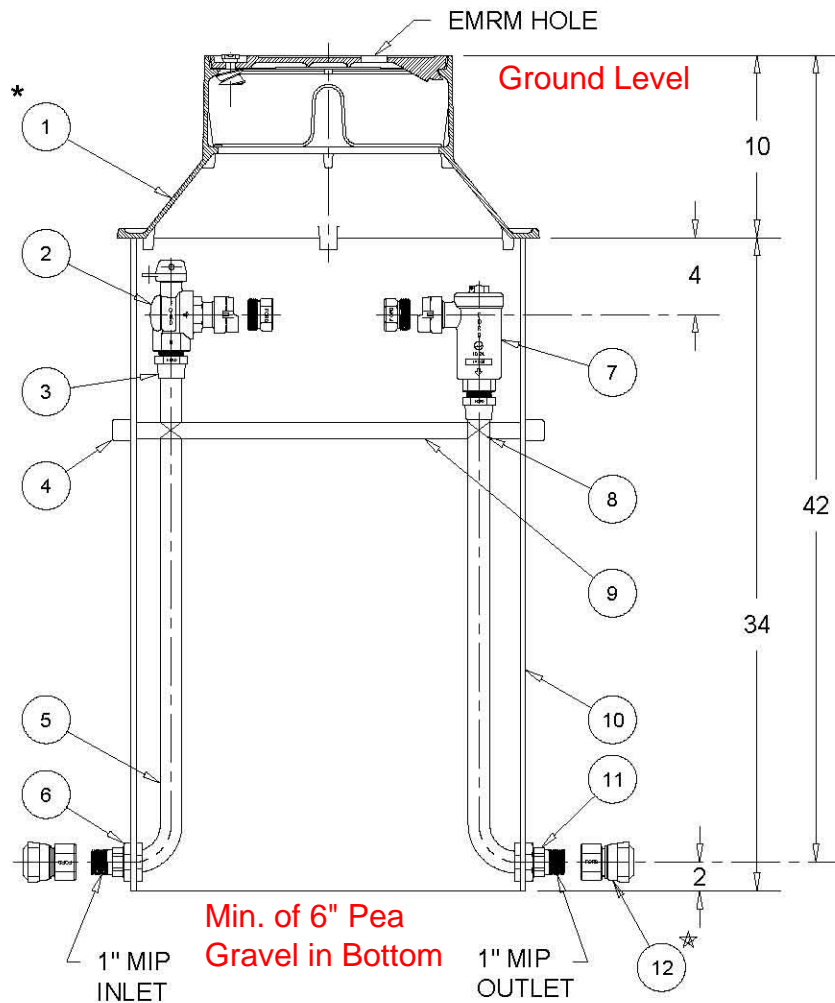

ITEM	DESCRIPTION	QTY.	DWG. OR P/N
* 1	METER BOX COVER W/EMRM	1	W3-T
2	ANGLE BALL VALVE	1	BA13-444W
3	SOLDER BUSHING	2	CS8-44
4	1/2" PVC CAP	2	050405
5	1 1/8 OD COPPER TUBE	2	
6	LOCK NUT	2	NOLN-1-02
7	ANGLE DUAL CART CHK VL 	1	HHCA31-444
8	PLASTIC TIE	2	300370
9	1/2" PVC BRACE BAR	1	PS-BB-20
10	20" ID PVC TILE	1	PVC-20X240-34
11	INLET/OUTLET PIECE	2	B-32009-01
12	COUPLING	2	C14-44-Q
13	ADAPTERS	1/PR	A34

* SOLD SEPARATELY
 ☆ SHIPPED UNASSEMBLED

PDBHC-444-C1080401

MATERIAL:

CAST GRAY IRON,
 ASTM A48-94, CLASS 25

ALL BRASS OF
 85-5-5-5 RED BRASS
 UNS C83600
 AWWA C800-05
 ASTM B62-02

NOTE: The curb box (or shut-off box) location must be outside of pit

ANGULAR	± N/A			ASSY. 20" PIT SETTER, 1" OR 3/4" METER, W/EMRM, 42" DEPTH	
DECIMAL	± N/A				
FRACTIONAL	± N/A				
DRAWN BY		DLG	DATE	2-21-06	DRAWING NO. A-10804-01
CHK'D BY		RLR	SCALE	1/10=1	

CIDS# 10804

REV.	DATE	DESCRIPTION	BY	TOLERANCE (Except as Noted)
				THE FORD METER BOX CO., INC. Wabash, Indiana 46992, U.S.A.

**** BACKFLOW MUST BE INSTALLED AFTER METER OUTSIDE OF PIT BEFORE WATER METER CAN BE INSTALLED ****